



# Gordian's KNOT

BRAINTEASER CHALLENGE



14+

single player

**TAKE-APART SOLUTION GUIDE**

## History of the original Gordian Knot

The original Gordian Knot is a famous story from the eighth century B.C. Asia Minor. As the story goes, the people had lost their king and their oracle announced that the next person to ride into town pulling an oxcart would be the new ruler. That person was Gordius, who, once crowned, tied up his cart with an extremely intricate knot. Over time, legend grew that the person who solved the knot would rule the world. For 400 years the knot remained a puzzle until Alexander the Great solved it and went on to rule great kingdoms.

Since ancient times, the Gordian Knot has been synonymous with the unsolvable puzzle. Today the tradition of the world's toughest puzzle continues. Our modern version will challenge your intellect and try your patience, but who knows, once you solve Gordian's Knot<sup>®</sup>, you too may rule great kingdoms.

# Gordian's KNOT

BRAINTEASER CHALLENGE

The World's Most Difficult  
Take-Apart Puzzle!

COMPONENTS:



RED



YELLOW



GREEN



BLUE



PURPLE



ORANGE

© 2010 ThinkFun Inc. All Rights Reserved. INZ

This side of the guide contains step-by-step instructions on how to take the puzzle apart. If you flip the guide over, you'll see instructions on how to put it back together.

### TAKING APART GORDIAN'S KNOT®

Slide the colored pieces back and forth, moving and removing pieces as you are able. To solve the puzzle, you'll have to discover the right combination of moves in order to remove the pieces. Sometimes you'll have to move several pieces together at the same time. There are no trick moves! You'll never have to rotate, turn, or use brute force on any of the pieces.

The image opposite shows a sample set of instructions.

The current step is described at the top of the page. On the left is an image of what the puzzle should look like before you perform the instruction. The right image shows what the puzzle will look like after the instruction.

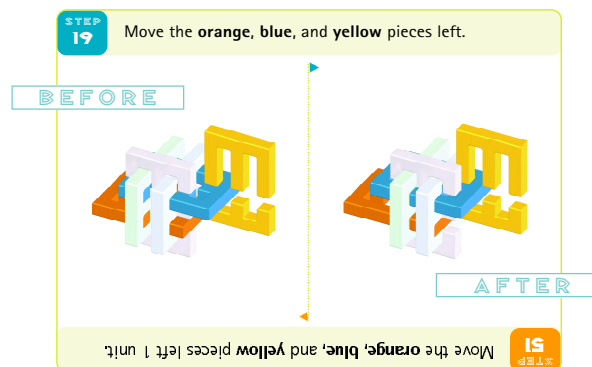

There are six possible directions a piece can move: left, right, up, down, toward you, and away from you. (The images in this guide have been turned to the left slightly so that you can see more of the puzzle).

### MOVING THE PIECES

Unless an instruction specifically says to do differently, you should move each piece as far as it will go.

**In each image, we've highlighted only the piece (or pieces) that move and muted all the other pieces.**

Some of the instructions will specify the number of "units" that a puzzle piece, or set of pieces, should be moved

**(a unit = the thickness of a puzzle piece—each piece is one unit thick, five units wide, and seven units long).**

In these cases, you need to be careful NOT to move the piece as far as it can go, and instead be careful to stop movement of the piece (or pieces) at the position indicated by the directions.

The picture diagram will help make this task clear.

Book design: George A. Miller

### ABOUT THE INVENTOR

Gordian's Knot® was invented by Frans de Vreugd, a Dutch puzzle inventor and originally named "Extreme Torture." The inventor used a computer program to determine the most difficult configuration possible for a six-piece puzzle.

### ABOUT THINKFUN®

ThinkFun® is the leading creator of mind challenging games. Since 1985, the company has produced award-winning games such as Rush Hour®, River Crossing®, and Aha! Brainteaser Classics™. Kids and adults alike look to ThinkFun to create hands-on, thought-provoking games that provide hours of fun-filled challenges. ThinkFun is committed to high-quality, innovative games that help people of all ages develop thinking skills through play. To learn more, please visit our website:

**[www.ThinkFun.com](http://www.ThinkFun.com)**

STEP 1

Move the **orange** piece left.

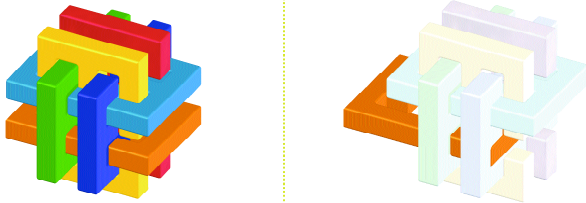

Move the **orange** piece left.

STEP 69

STEP 2

Move the **green** piece away from you.

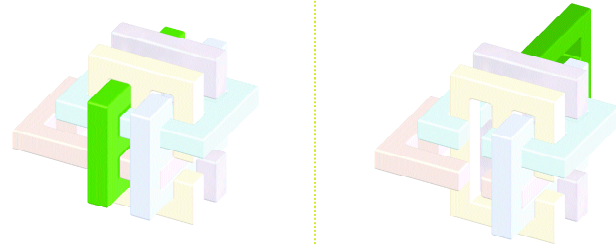

Move the **green** piece toward you.

STEP 68

STEP  
3

Move the **orange** piece right.

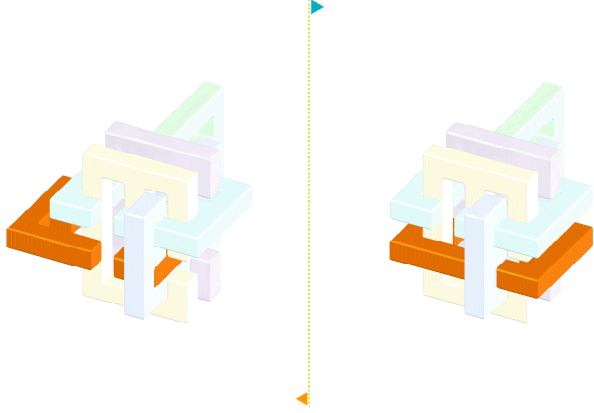

Move the **orange** piece right.

STEP  
67

STEP  
4

Move the **yellow** piece down.

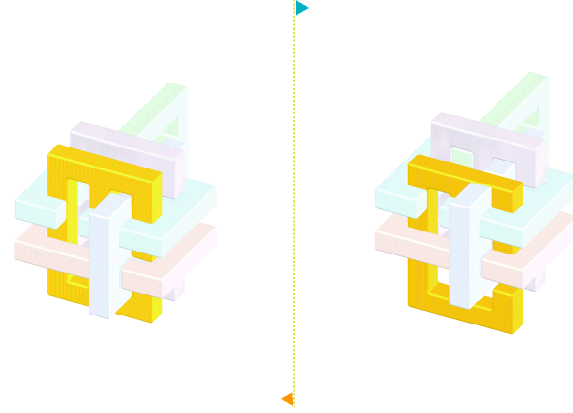

Move the **yellow** piece down.

STEP  
66

STEP  
5

Move the **blue**, **orange**, and **yellow** pieces left.

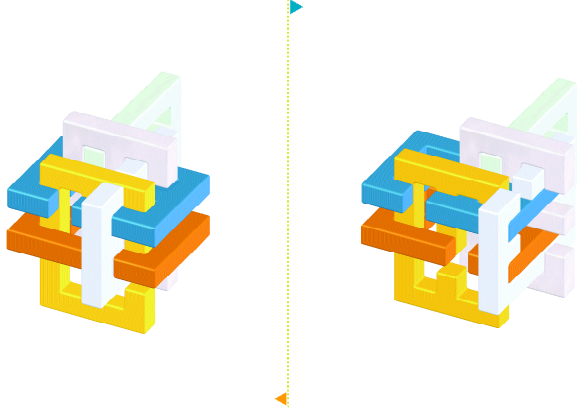

Move the **blue**, **orange**, and **yellow** pieces left.

STEP  
5

STEP  
6

Move the **yellow** piece up 3 units.

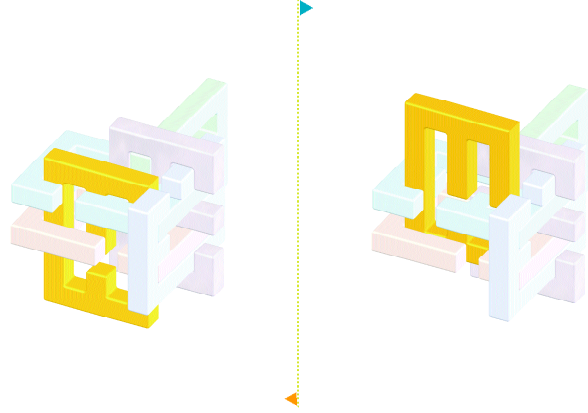

Move the **yellow** piece up.

STEP  
6



**STEP 7** Move the **yellow** and **orange** pieces right.

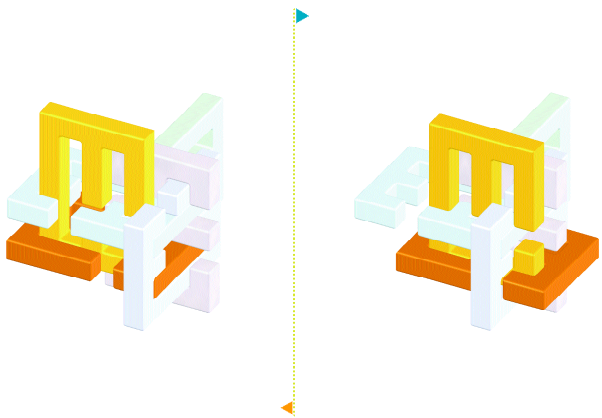

**STEP 63** Move the **yellow** and **orange** pieces right.

The diagram for Step 7 shows two isometric views of a partially assembled structure. The left view shows a central structure with a yellow piece and an orange piece positioned below it. A vertical dashed arrow points from the left view to the right view. The right view shows the yellow and orange pieces moved to the right, now resting on a light blue base. The text 'STEP 7 Move the yellow and orange pieces right.' is at the top, and 'STEP 63 Move the yellow and orange pieces right.' is at the bottom.

**STEP 8** Move the **yellow** piece up.

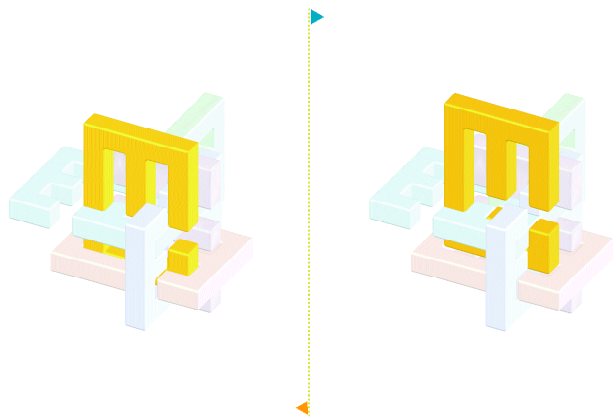

**STEP 62** Move the **yellow** piece up.

The diagram for Step 8 shows two isometric views of the assembly. The left view shows the yellow piece positioned below a slot in the structure. A vertical dashed arrow points from the left view to the right view. The right view shows the yellow piece moved up and inserted into the slot. The text 'STEP 8 Move the yellow piece up.' is at the top, and 'STEP 62 Move the yellow piece up.' is at the bottom.

STEP  
9

Move the **orange** piece left.

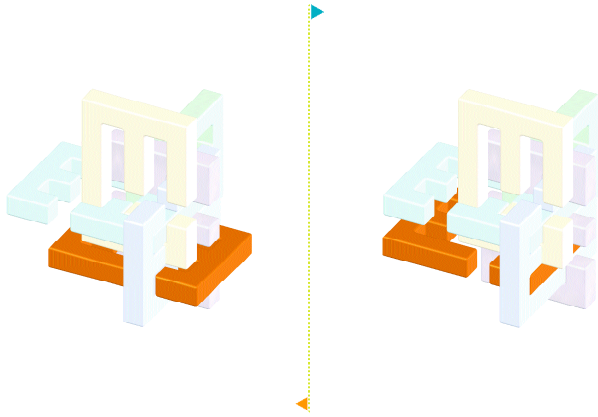

Move the **orange** piece left.

STEP  
9

STEP  
10

Move the **blue** and **yellow** pieces right 2 units.

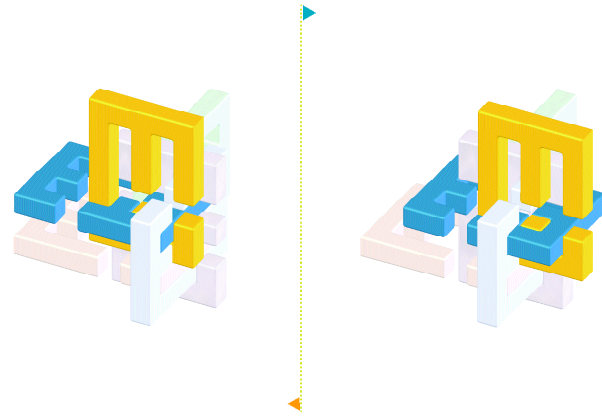

Move the **blue** and **yellow** pieces right.

STEP  
10

STEP  
11

Move the **green** piece toward you.

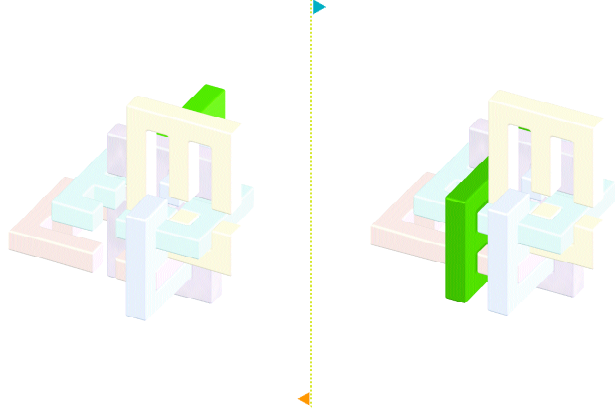

Move the **green** piece away from you 3 units.

STEP  
59

STEP  
12

Move the **blue** and **yellow** pieces right.

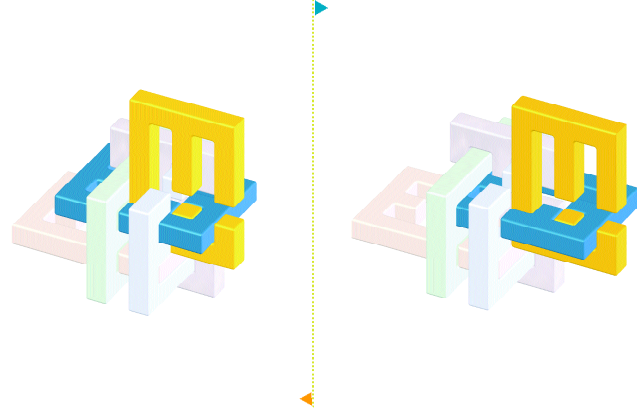

Move the **blue** and **yellow** pieces right.

STEP  
58

**STEP 13** Move the **yellow** piece down 1 unit.

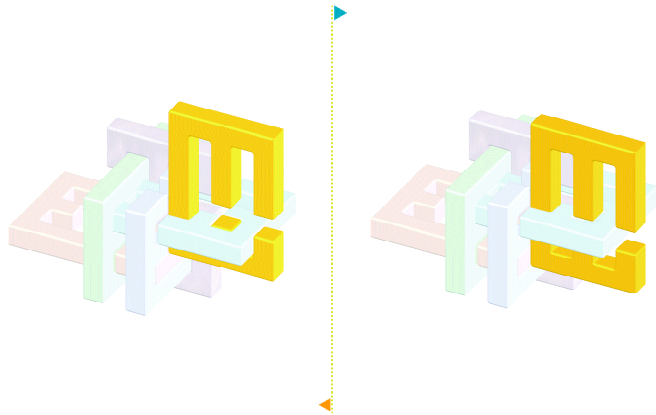

**STEP 14** Move the **yellow** piece toward you.

**STEP 14** Move the **yellow** piece away from you.

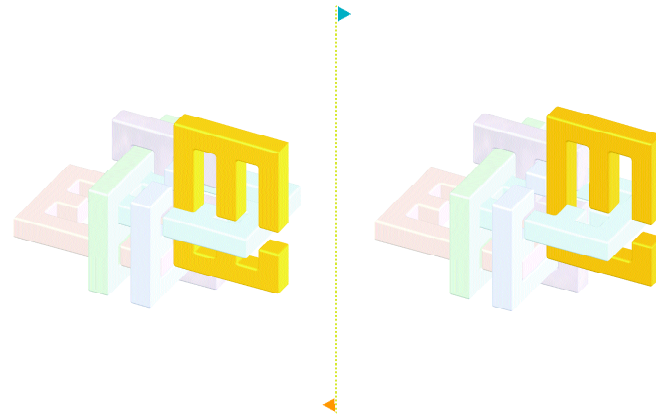

**STEP 15** Move the **yellow** piece toward you.

STEP  
15

Move the **orange** and **yellow** pieces right.

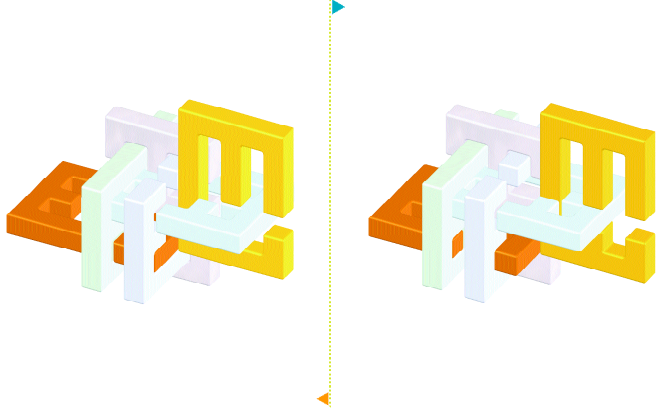

Move the **orange** and **yellow** pieces right.

STEP  
15

STEP  
16

Move the **yellow** piece away from you.

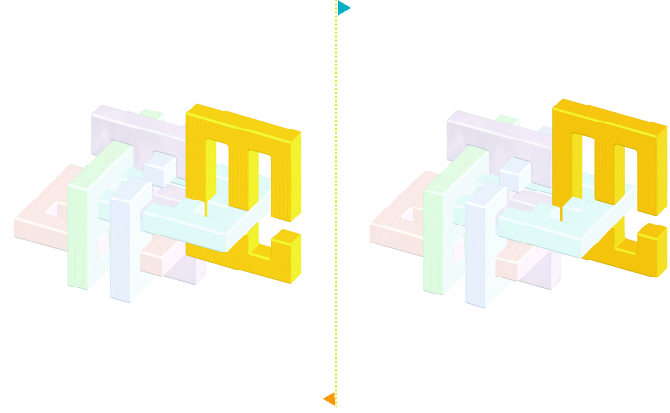

Move the **yellow** piece toward you.

STEP  
16

**STEP 17** Move the **blue** piece left.

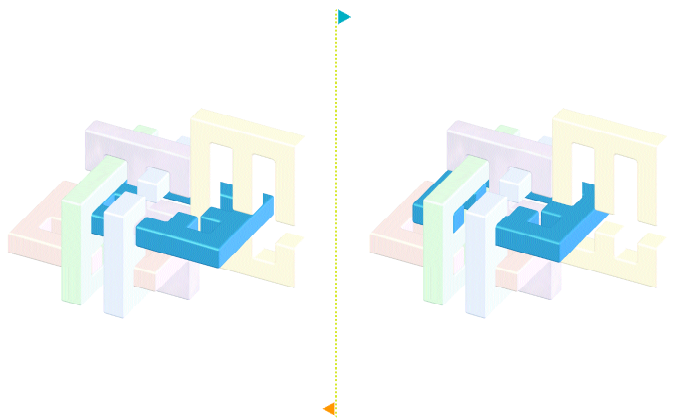

**STEP 53** Move the **blue** piece left.

**STEP 18** Move the **red** piece toward you.

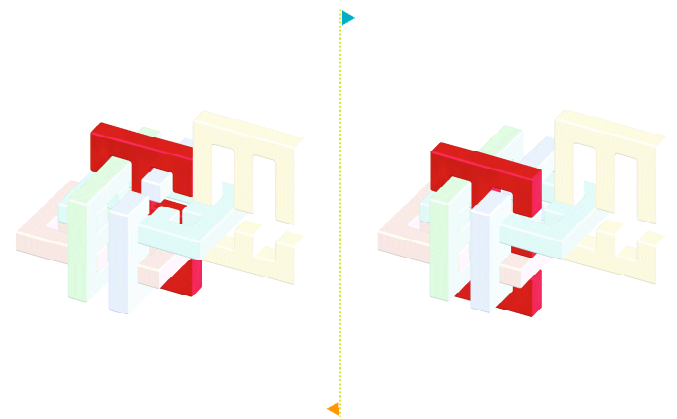

**STEP 52** Move the **red** piece away from you.

STEP  
19

Move the **orange, blue, and yellow** pieces left.

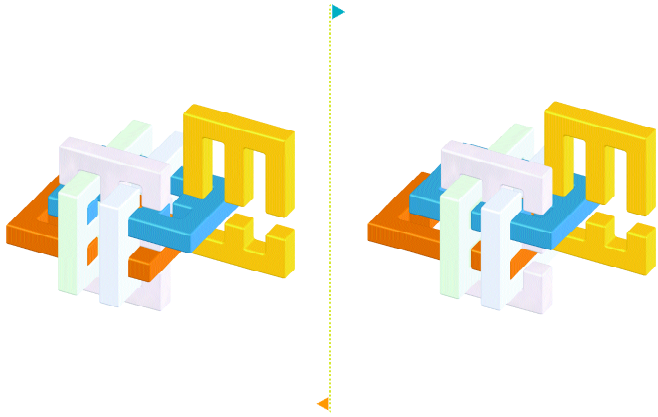

Move the **orange, blue, and yellow** pieces left 1 unit.

STEP  
19

STEP  
20

Move the **green** piece away from you.

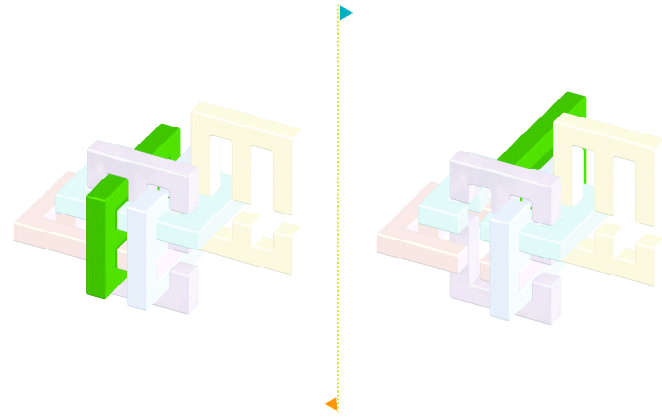

Move the **green** piece toward you.

STEP  
20

STEP  
21

Move the **green** piece left.

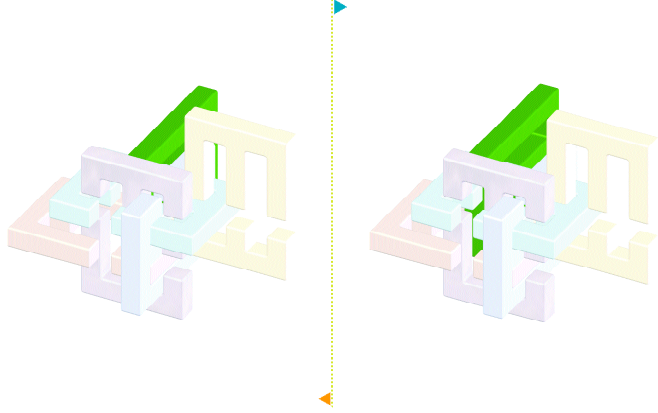

Move the **green** piece left 1 unit.

STEP  
49

STEP  
22

Move the **red** and **purple** pieces left.

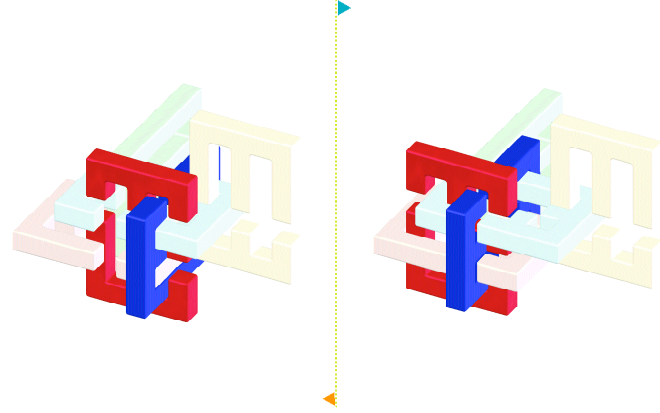

Move the **red** and **purple** pieces left.

STEP  
48



STEP  
23

Move the **red** piece down.

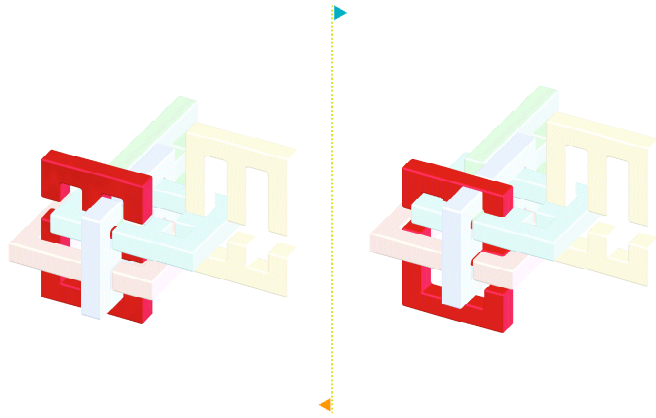

Move the **red** piece down.

STEP  
47

STEP  
24

Move the **purple** piece right.

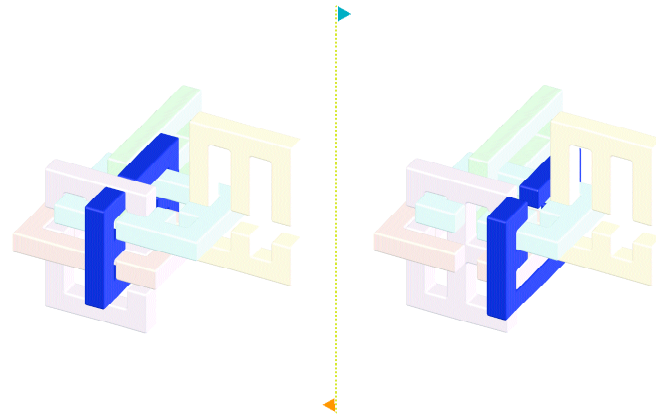

Move the **purple** piece right.

STEP  
46

STEP 25

Move the **red** piece up.

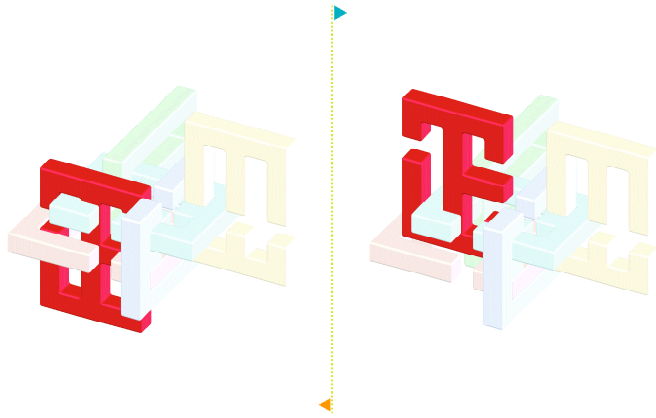

Move the **red** piece up.

STEP 25

STEP 26

Move the **orange** piece left 1 unit.

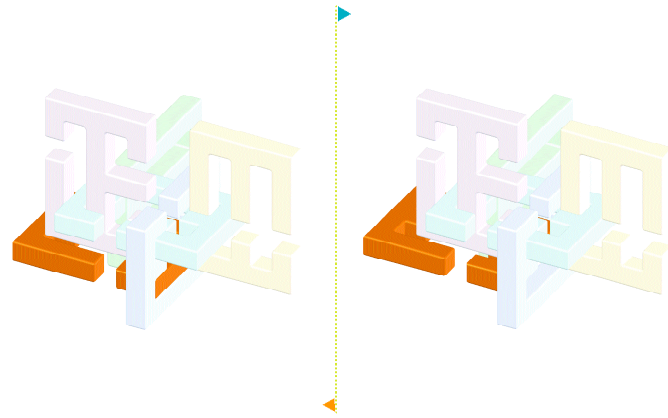

Move the **orange** piece left.

STEP 26

STEP  
27

Move the **orange** piece away from you.

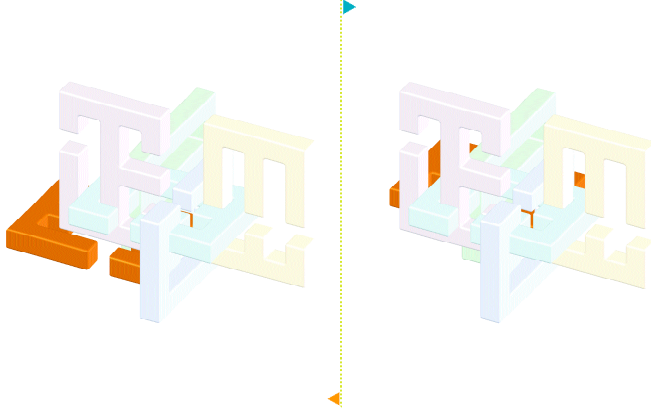

Move the **orange** piece toward you.

STEP  
43

STEP  
28

Move the **orange** piece left out of the puzzle.

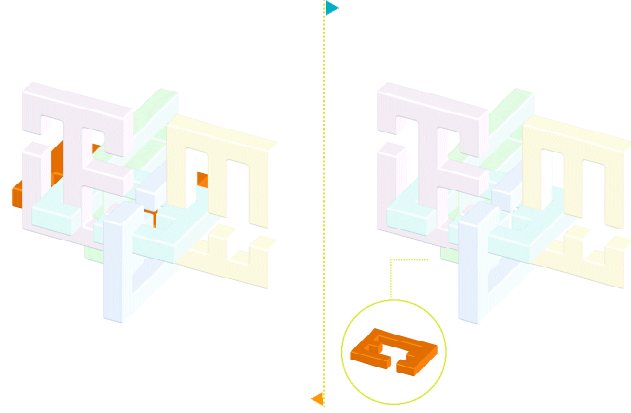

Move the **orange** piece left into the puzzle (into green piece).

STEP  
42

STEP  
29

Move the **red** piece down.

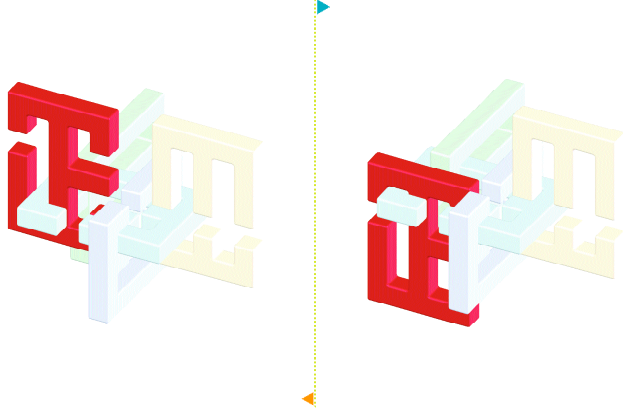

Move the **red** piece down.

STEP  
41

STEP  
30

Move the **purple** piece left.

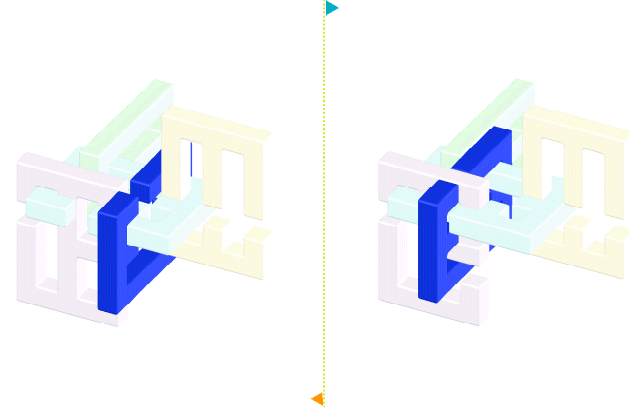

Move the **purple** piece left.

STEP  
40

STEP  
31

Move the **red** piece up.

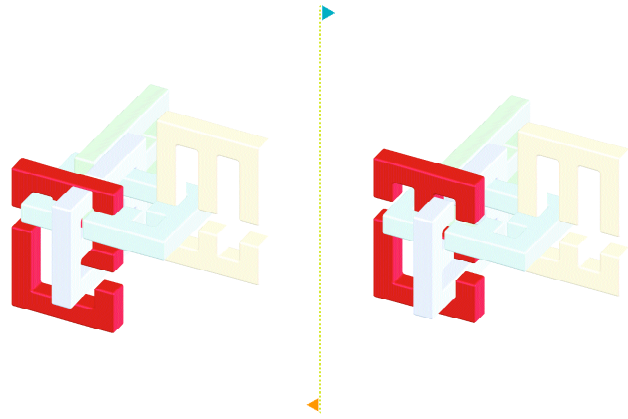

Move the **red** piece up.

STEP  
39

STEP  
32

Move the **red** and **purple** pieces right.

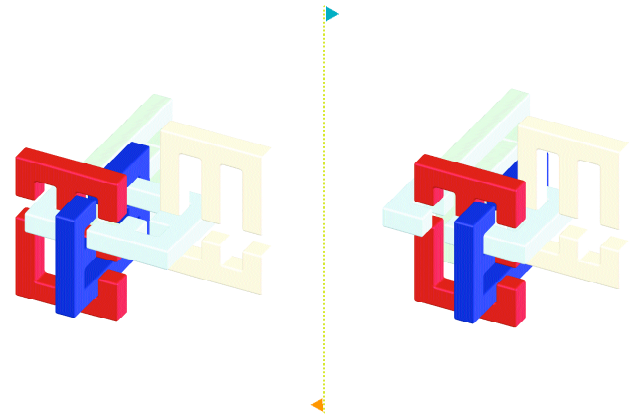

Move the **red** and **purple** pieces right.

STEP  
38

STEP  
33

Move the **green** piece right 1 unit.

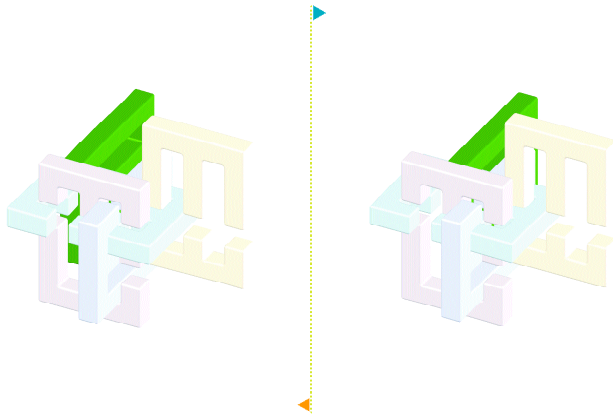

Move the **green** piece right.

STEP  
37

STEP  
34

Move the **green** piece toward you.

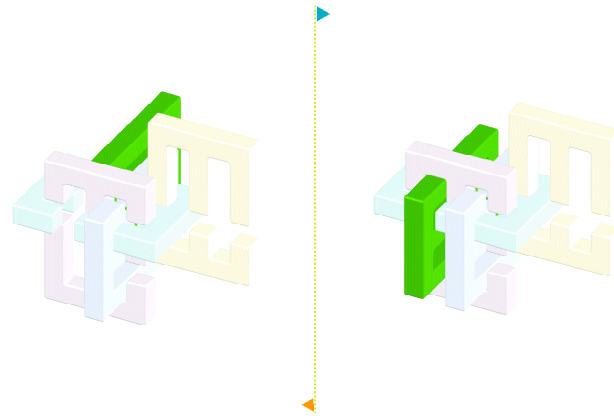

Move the **green** piece away from you.

STEP  
36

STEP  
35

Move the **yellow** and **blue** pieces right 1 unit.

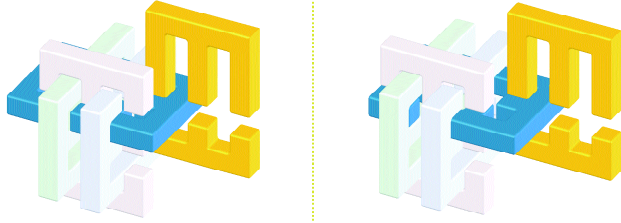

Move the **yellow** and **blue** pieces right.

STEP  
35

STEP  
36

Move the **red** piece away from you.

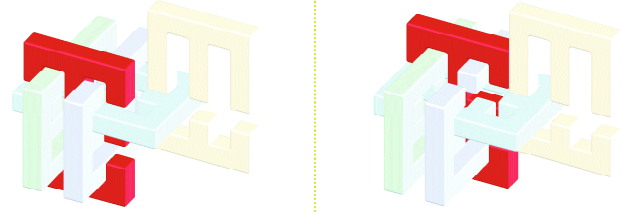

Move the **red** piece toward you.

STEP  
36

STEP  
37

Move the **blue** piece right.

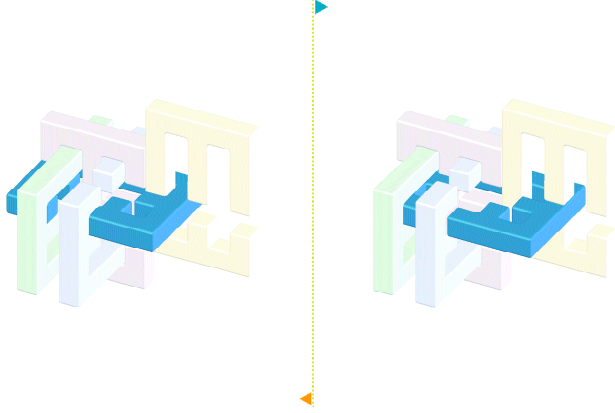

Move the **blue** piece right.

STEP  
33

STEP  
38

Move the **yellow** piece toward you.

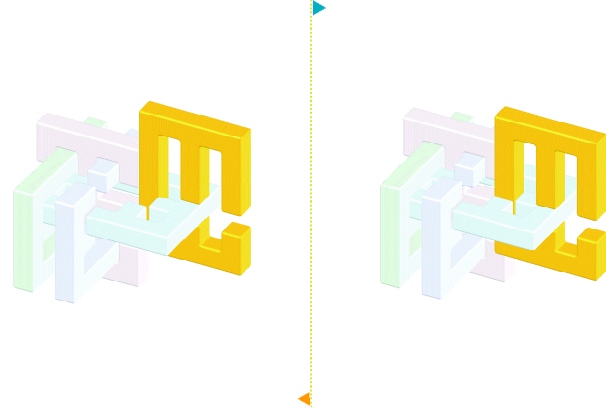

Move the **yellow** piece away from you.

STEP  
32



STEP  
39

Move the **yellow** piece left.

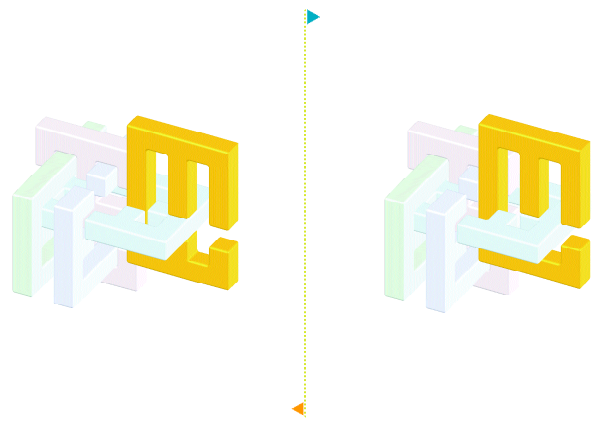

STEP  
31

Move the **yellow** piece left.

STEP  
40

Move the **yellow** piece toward you.

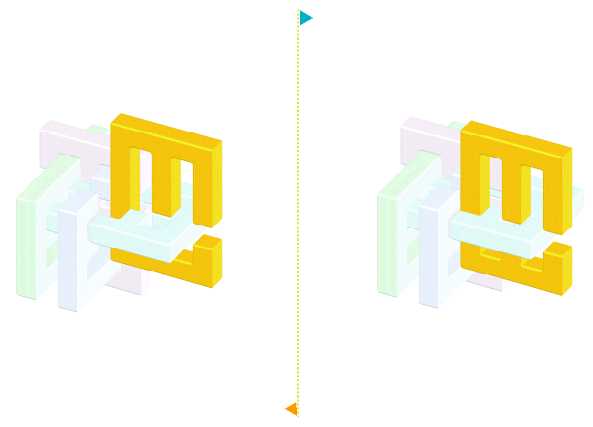

STEP  
30

Move the **yellow** piece away from you.

STEP  
41

Move the **yellow** and **blue** pieces left.

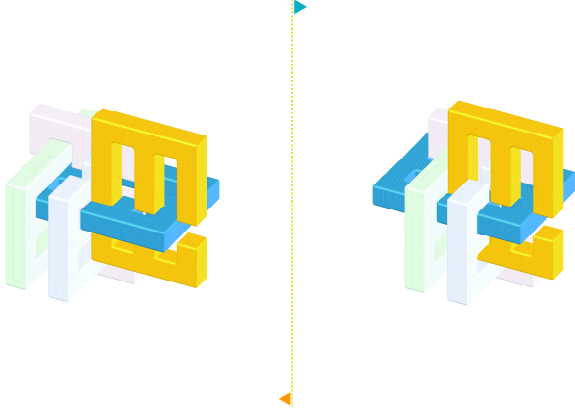

Move the **yellow** and **blue** pieces left.

STEP  
29

STEP  
42

Move the **green** piece away from you.

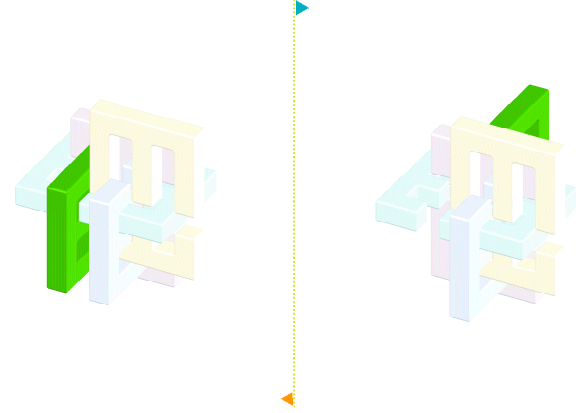

Move the **green** piece toward you.

STEP  
28

STEP  
43

Move the **yellow** and **blue** pieces left 1 unit.

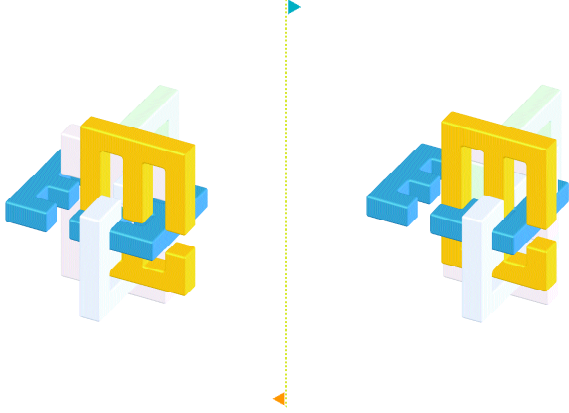

Move the **yellow** and **blue** pieces left 1 unit.

STEP  
27

STEP  
44

Move the **red** piece toward you.

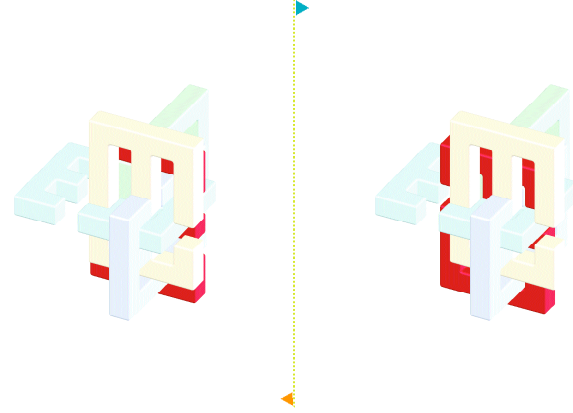

Move the **red** piece away from you.

STEP  
26

STEP  
45

Move the **green** piece left.

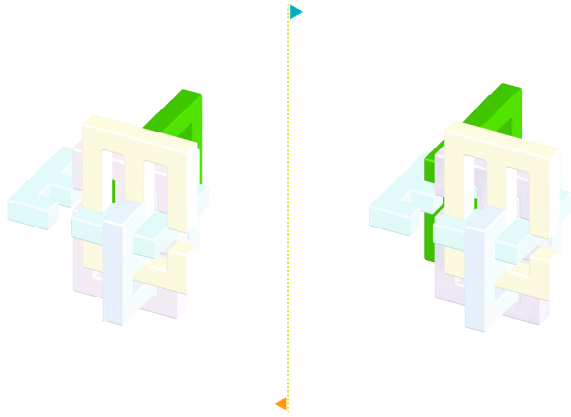

Move the **green** piece left 2 units.

STEP  
45

STEP  
46

Move the **red** piece away from you.

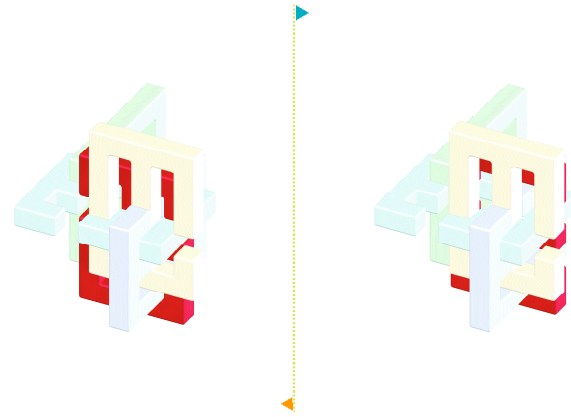

Move the **red** piece toward you.

STEP  
46

STEP  
47

Move the **yellow** and **blue** pieces left.

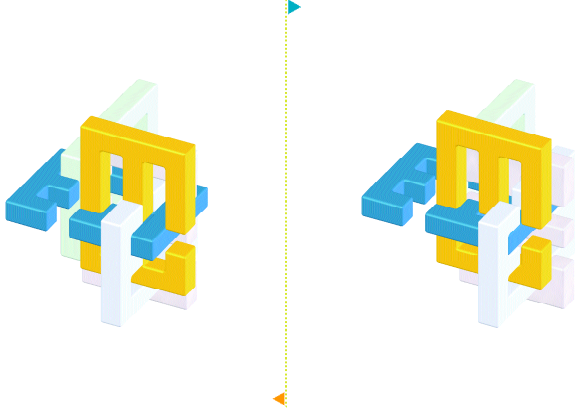

Move the **yellow** and **blue** pieces left.

STEP  
48

STEP  
48

Move the **green** piece toward you.

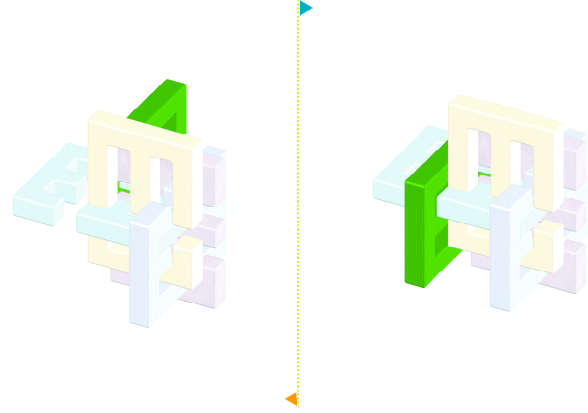

Move the **green** piece away from you.

STEP  
49

**STEP 49** Move the **green** piece left out of the puzzle.

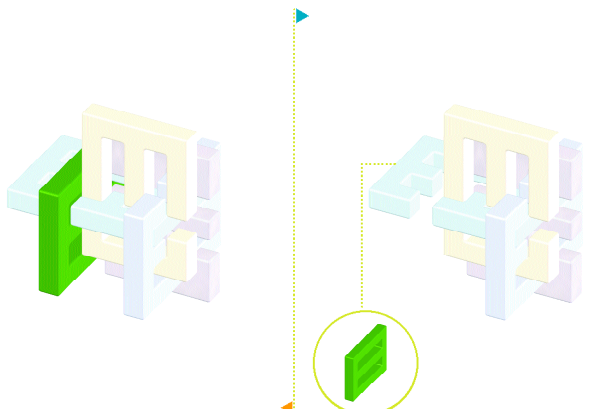

The diagram shows a 3D puzzle structure with a green piece on the left side. A vertical dashed arrow points from the green piece to a circular inset below it, which shows the green piece being moved to the left. The puzzle structure consists of light blue, yellow, and purple pieces.

**STEP 51** Move the **green** piece left into the puzzle.

**STEP 50** Move the **yellow** piece left.

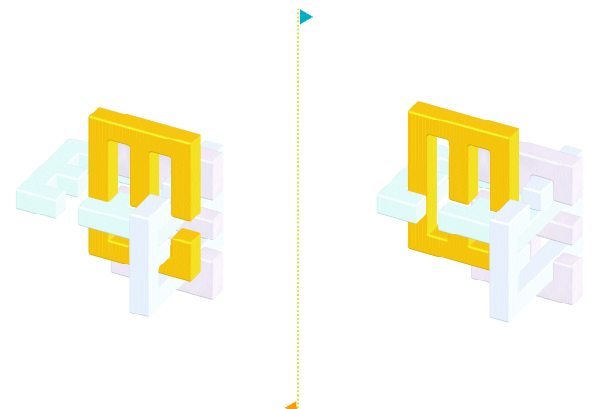

The diagram shows a 3D puzzle structure with a yellow piece on the right side. A vertical dashed arrow points from the yellow piece to a circular inset below it, which shows the yellow piece being moved to the left. The puzzle structure consists of light blue, yellow, and purple pieces.

**STEP 52** Move the **yellow** piece left.

STEP  
51

Move the **yellow** piece down.

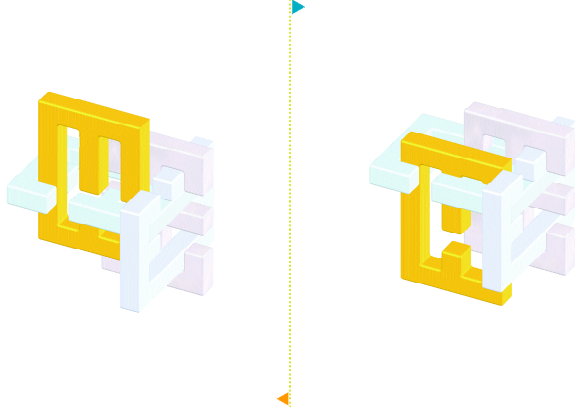

Move the **yellow** piece down 3 units.

STEP  
19

STEP  
52

Move the **red** and **purple** pieces left.

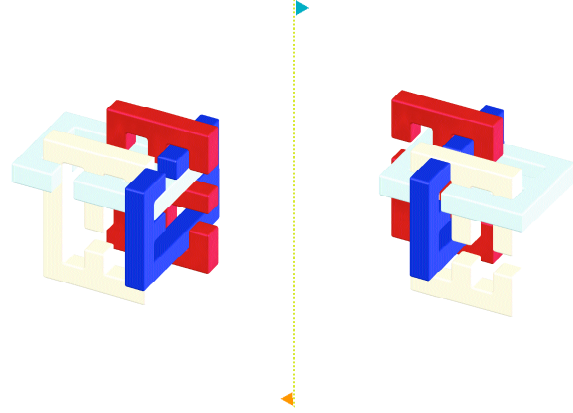

Move the **red** and **purple** pieces left.

STEP  
18

STEP 53

Move the **yellow** piece up.

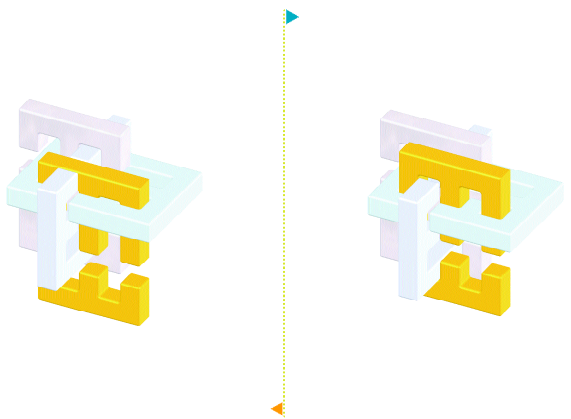

STEP 54

Move the **yellow** piece up.

STEP 54

Move the **purple** piece away from you.

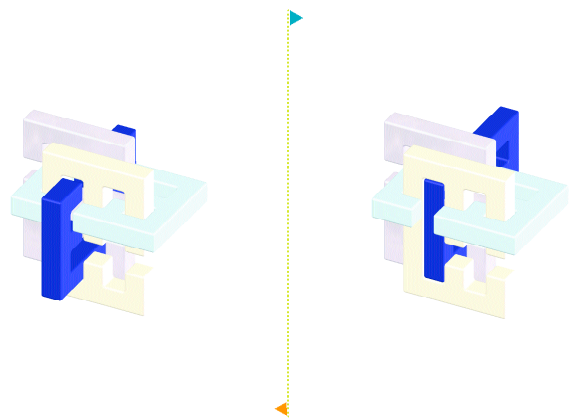

STEP 55

Move the **purple** piece toward you.



STEP  
55

Move the **blue** piece down.

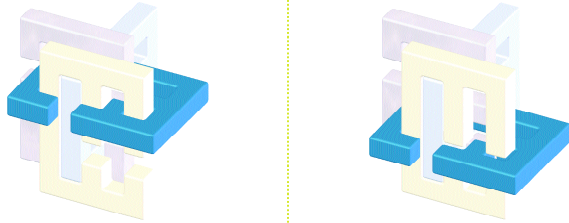

Move the **blue** piece down.

STEP  
55

STEP  
56

Move the **red** piece down.

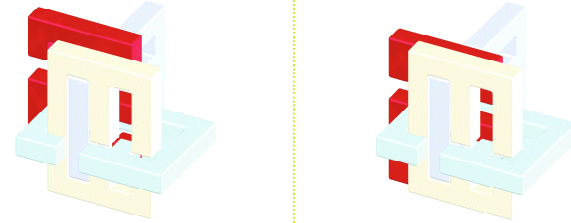

Move the **red** piece down.

STEP  
56

STEP  
57

Move the **yellow** and **purple** pieces right.

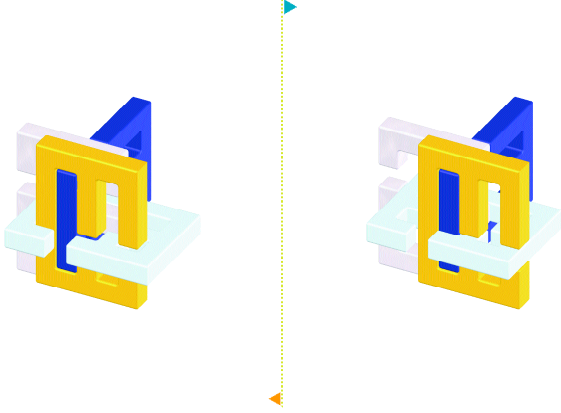

Move the **yellow** and **purple** pieces right.

STEP  
13

STEP  
58

Move the **yellow** piece toward you out of the puzzle.

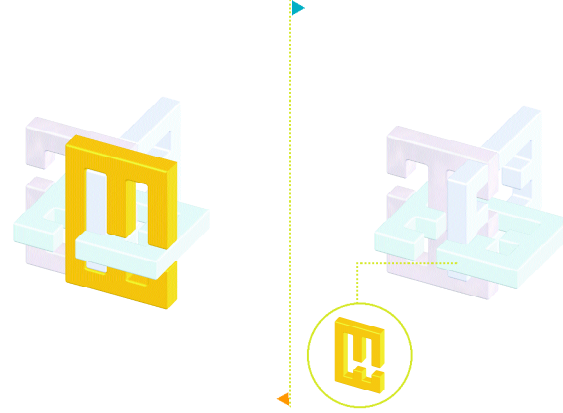

Move the **yellow** piece away from you 2 units into the puzzle.

STEP  
12

STEP  
59

Move the **purple** piece left.

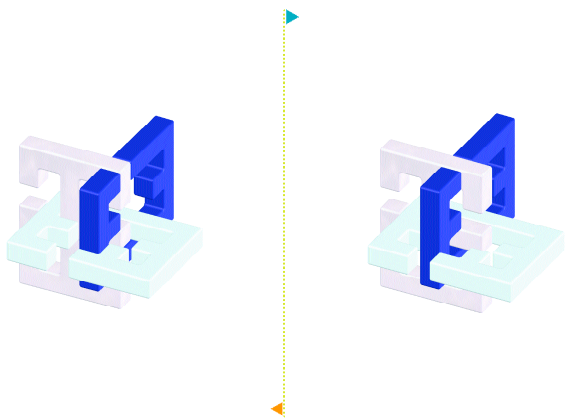

STEP II  
Move the **purple** piece left.

STEP  
60

Move the **red** piece up.

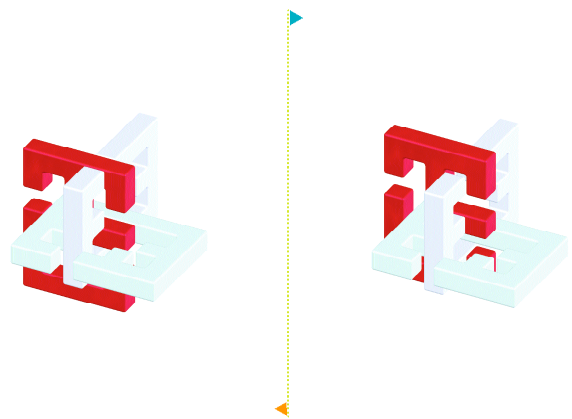

STEP OI  
Move the **red** piece up.

**STEP 61** Move the **blue** piece up.

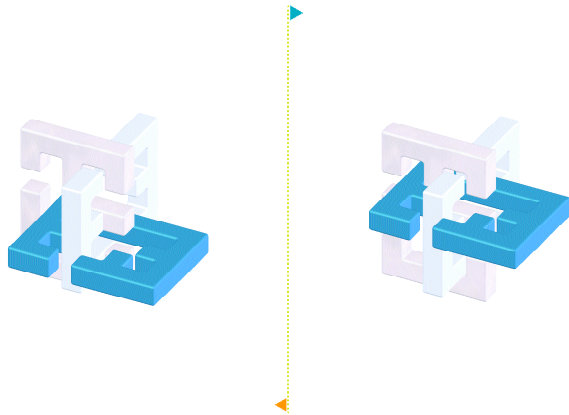

**STEP 6** Move the **blue** piece up.

**STEP 62** Move the **purple** piece toward you.

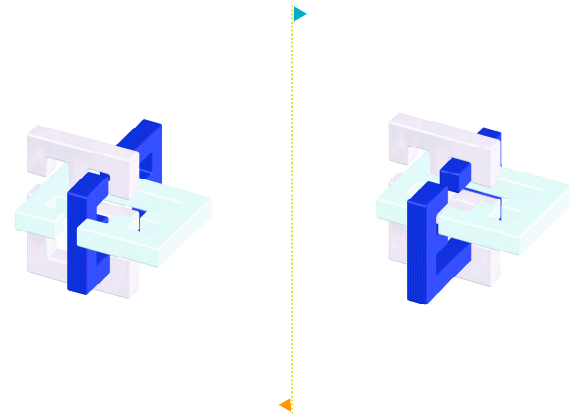

**STEP 8** Move the **purple** piece away from you.

STEP  
63

Move the **blue** piece left 2 units.

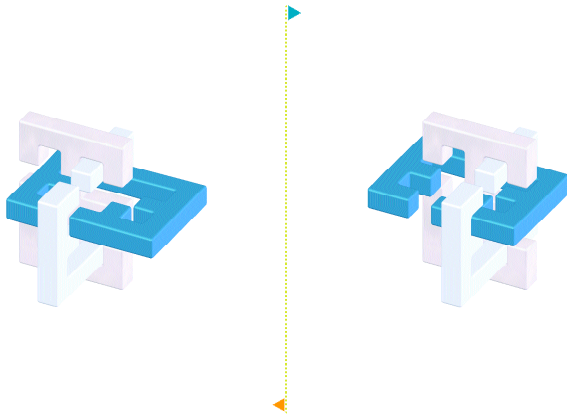

Move the **blue** piece left.

STEP  
7

STEP  
64

Move the **red** piece toward you.

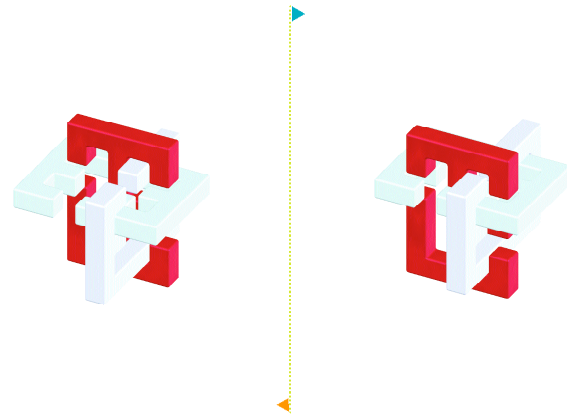

Move the **red** piece away from you.

STEP  
9

STEP  
65

Move the **red** piece down.

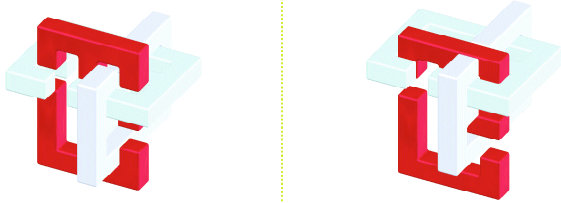

Move the **red** piece down.

STEP  
65

STEP  
66

Move the **purple** piece right out of the puzzle.

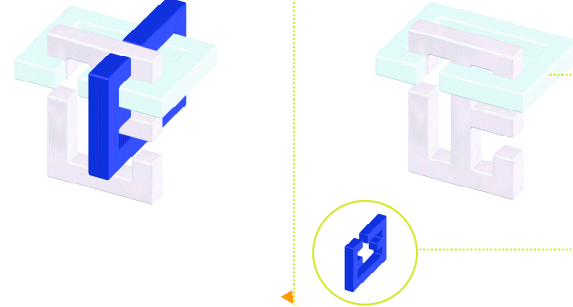

Move the **purple** piece right into the puzzle.

STEP  
66

**STEP 67** Move the **red** piece up.

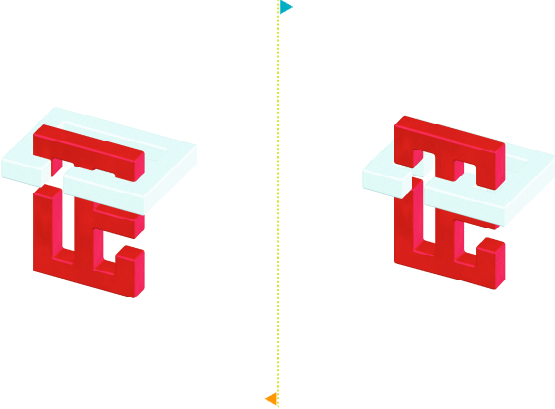

The diagram shows two states of a red piece on a light blue base. On the left, the red piece is partially inserted into the base. On the right, it is fully inserted and pushed up. A vertical dashed arrow with a blue arrowhead at the top and an orange arrowhead at the bottom indicates the upward movement.

**STEP 3** Move the **red** piece up.

**STEP 68** Move the **red** piece left 1 unit.

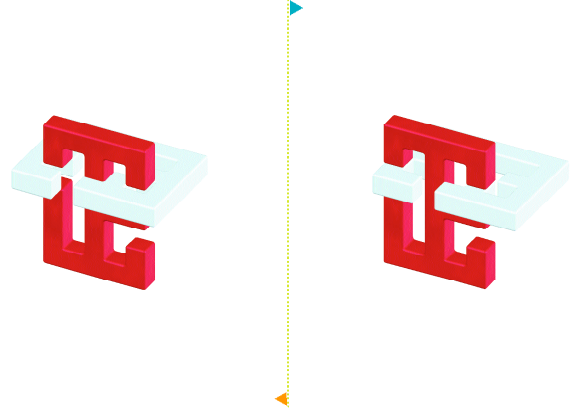

The diagram shows two states of a red piece on a light blue base. On the left, the red piece is shifted to the right side of the base. On the right, it is shifted to the left side. A vertical dashed arrow with a blue arrowhead at the top and an orange arrowhead at the bottom indicates the movement.

**STEP 2** Move the **red** piece left.

STEP  
69

Move the **red** piece toward you out of the puzzle.

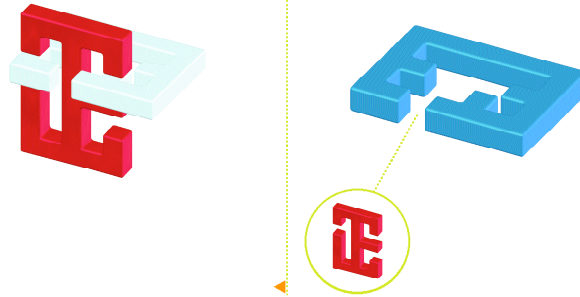

Move the **red** piece away from you 2 units into the blue piece.

STEP  
70



## PUTTING GORDIAN'S KNOT® BACK TOGETHER

Putting Gordian's Knot® back together uses the same solution sequence as does taking it apart, except you follow all the steps in reverse order.

To help you with inserting a new piece into the puzzle, we have highlighted an image of that piece in its correct orientation in the corner of the page.

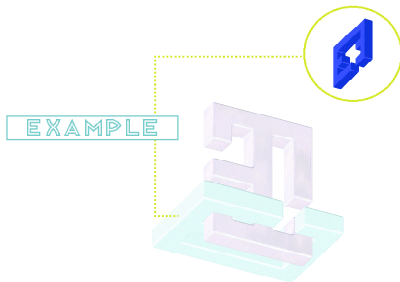



# Gordian's KNOT

**BRAINTEASER CHALLENGE**



**14+**

single player

**ASSEMBLE SOLUTION GUIDE**