



Instructions

MakerStudio™

Propellers Set



Rubber Band
Powered!

Potato Chip Chopper

**YOU CAN
ALSO MAKE:**

Biplane
Plane
Windmill



WARNING:

Toy contains functional sharp point.
CHOKING HAZARD—Small parts.
Not for CHILDREN UNDER 3YRS.

AGES **7** TO ADULT

DESIGNED BY ENGINEERS FOR BUDDING ENGINEERS!

Using your maker parts, have fun turning things from your recycle bin into machines that move. In this set featuring propellers, you can build a chopper, a biplane, a plane and a windmill. Once you've completed a build, put your creative thinking skills to the test by taking an Engineering Challenge. There are two for each build plus two bonus challenges--you'll have to think like a true engineer as you design your solutions.

PARTS/INVENTORY

- 1 X-linkage
- 1 Spool
- 2 Extra Long Connectors
- 3 Long Connectors
- 4 Short Connectors
- 2 Small Wheels
- 5 1.5" Rods
- 3 4.25" Rods
- 1 5.5" Rod
- 24 Hub Caps
- 1 Hole Punch
- 3 Rubber Bands
- 10 Engineering Challenges

You'll Also Need:

- Objects such as a potato chip can, a toilet paper tube and a water bottle.
- A pencil or pen
- Tape or glue
- Scissors
- Decorations (paint, stickers, glitter, etc.)
- Creativity!

(Note: your recycle bin is a good place to look. The measurements we've listed on the builds are just suggestions—use what you have.)

SIMPLE STEPS

1. Choose a build and gather the parts needed, including a recyclable object. Before building, familiarize yourself with the parts. You'll find an explanation for how to use several of the parts starting on page 3.
2. Follow the step-by-step assembly instructions. You may want to work with an adult or older child to help with cutting some of the recyclable objects.

3. Decorate your build!—Paint flames on the side, wrap it in shiny paper or adorn it with stickers, duct tape and glitter. Get creative and go for it!
4. Once you've had some fun with your creation, take the Engineering Challenges (each build comes with two.) Note: you will need to alter your build to solve each challenge. There is no single solution, so have fun being innovative!
5. After completing all four builds in the set, use your new engineering skills to design and build your own unique solution for Challenges 9 & 10.

Go to www.ThinkFun.com/MakerStudio to see all the Maker Studio sets and combine them for more building fun!

PARTS EXPLANATION

Before building, take note of how the parts listed below can be used.

- a. **Spool:** Use the spool to secure and wrap a rubber band, string, or similar object around a rod. When wrapping and winding a rubber band around the spool, you create tension which can be released to power a wheel or gear.

To use the spool, tie a string or loop a rubber band around the small tab in the center of the spool. Then wind the string or rubber band around the middle of the spool.

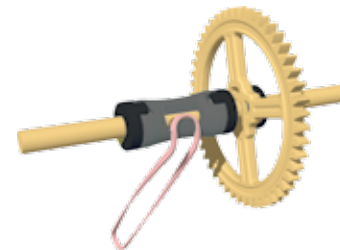

When reading the assembly instructions, pay close attention to the direction the tab is facing on the spool. This will be important to power the machine.

- b. **Connectors:** Use the connectors to join multiple rods and allow some or all of these rods to rotate in place.

- c. **Gears:** Use the gears to change the direction of force, and transfer this force between gears and wheels.
- d. **Rods:** Use the rods to connect multiple parts along a single axis, often at least one of those parts is intended to rotate around that axis.
- e. **Hub Caps:** Use hub caps to secure parts (i.e. wheels or gears) to a rod. Based upon how you attach the hub cap, you can either lock a part in place or allow the part to spin freely.

To lock a part in place, use the two teeth found on one side of the hub cap. These teeth are designed to fit into the slots on the connectors, wheels and gears.

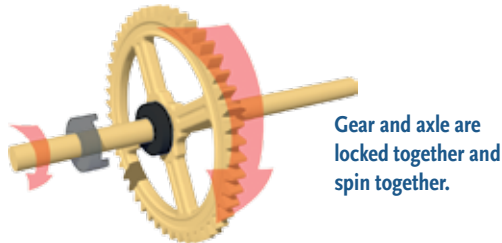

To allow a part to spin freely, turn the hub cap so the teeth are facing out and do not lock into the slots on the connectors, wheels or gears.

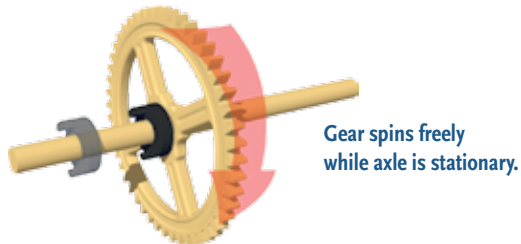

Note: When reading the assembly instructions, pay close attention to which direction the teeth are facing.

- f. **Hole Punch:** Use the hole punch to make holes in your recyclable household items. This hole punch creates a hole that is the perfect size for your rods to fit through. NOTE: When using the hole punch you may have to support the object with your other hand so that it does not crumple; however, take care not to place your hand directly opposite the pointy end of the hole punch.

ABOUT THE INVENTORS

Parker Thomas has been a maker his entire life. He has built and sold two companies, cofounded a public Montessori charter school and built two airplanes. In his spare time he makes tree houses, zip lines, drones, boats, pens, knives and anything else his two kids want to make. As a child, Parker's house was littered with the carcasses of old cameras, tape recorders, engines and dozens of other devices sacrificed in his quest to understand how things work. After building a 200 mph, two-seat, aerobatic airplane from a kit he began to understand the power of making as a learning process. This led him to create maker spaces in schools, develop curriculum for 3-D printing and ultimately to co-found a school based on the principles of Montessori, design thinking and arts integration. He's currently a consultant helping schools and other learning organizations create maker mindsets and spaces that encourage creativity and learning.

David Yakos: Driven by creativity and a background in Mechanical Engineering, he pursued the world of consumer product design and prototyping. With an early start at the age of five, his parents set up "David's Creative Corner" in the house which consisted of a cut-down dryer box full of empty shampoo bottles, paper tubes, popsicle sticks and other building supplies. There, with his imagination, he was able to begin his journey of design and invention. Today, David continues to develop consumer products as Director of Creativity, and Co-Owner of a product design firm called Salient Technologies Inc. He spends nearly every day of his life inventing unique solutions for everyday problems. Named on dozens of patents, he has helped develop hundreds of products for startups and leading brands; from lines of wheelchairs for children to award-winning dog toys; from breakthrough cryogenic valve technology for NASA, to a prototype-of-the-year noted by Popular Science.

David and Parker met at the Hatch Experience and were inspired to share these kits with the world #BecauseOfHATCH

Potato Chip Chopper

ENGINEERING CHALLENGE #1

ENGINEERING CHALLENGE #2

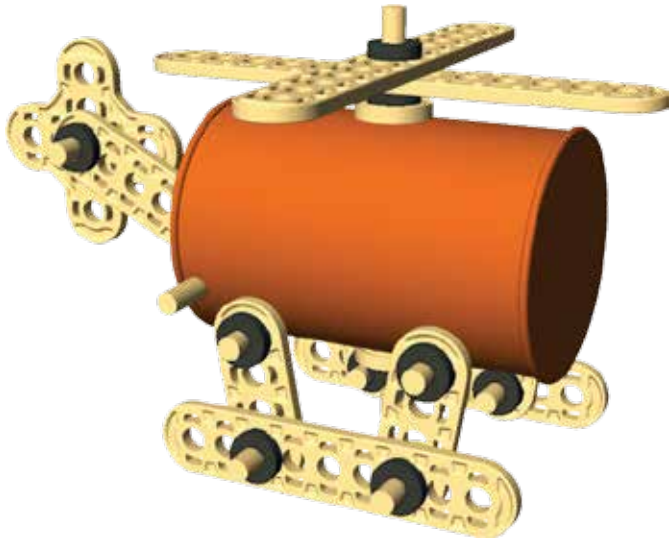
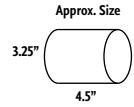

1.

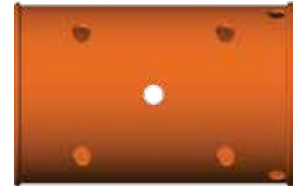
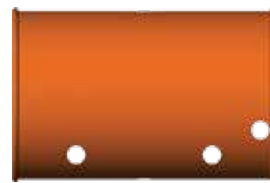
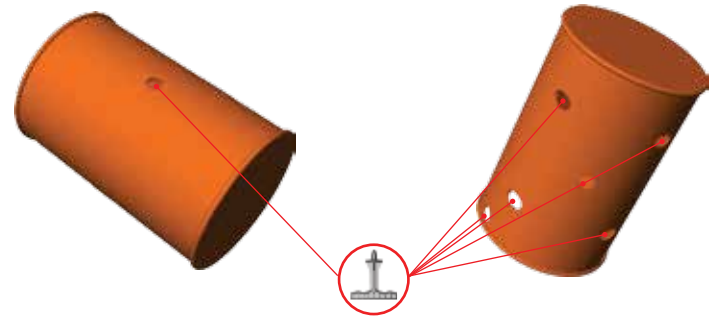

Parts needed:

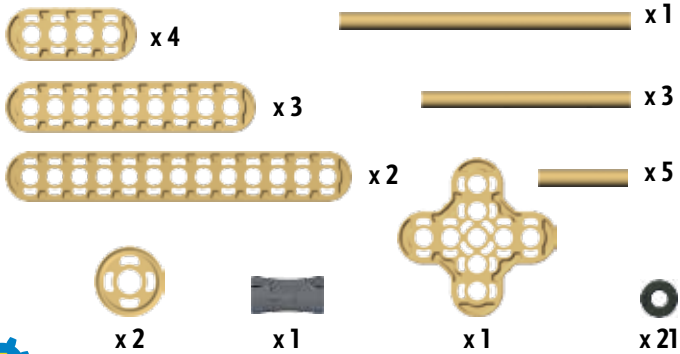

Tools:



2.

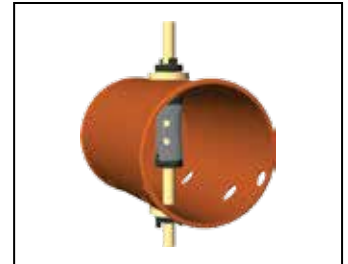
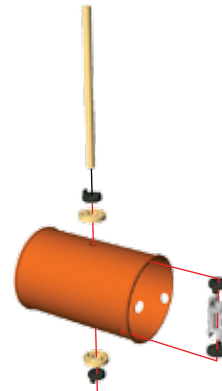

3. _____

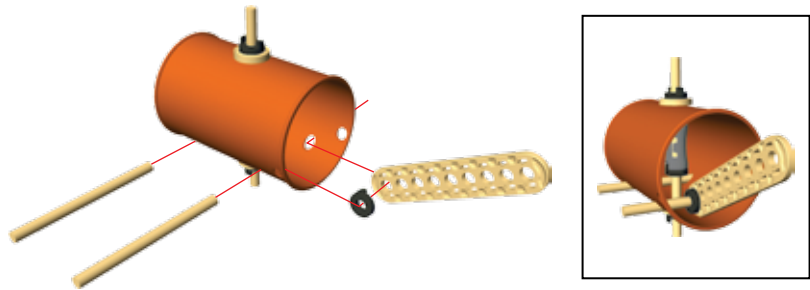

4. _____

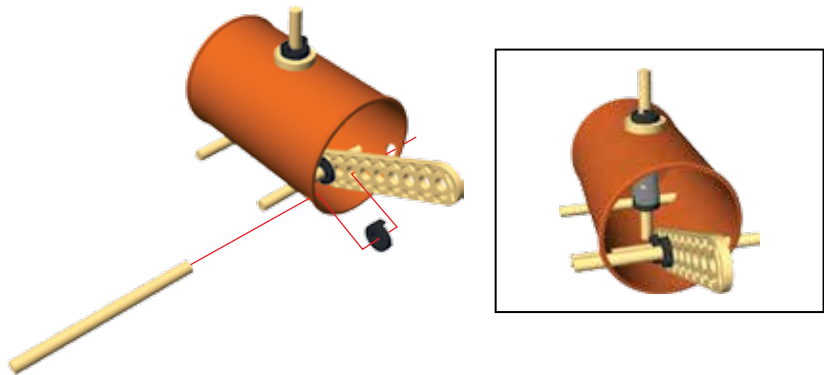

5. _____

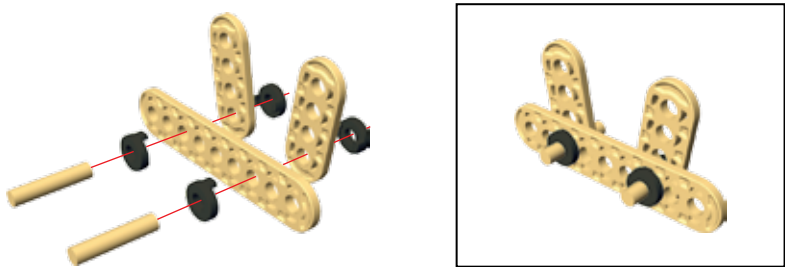

6. _____

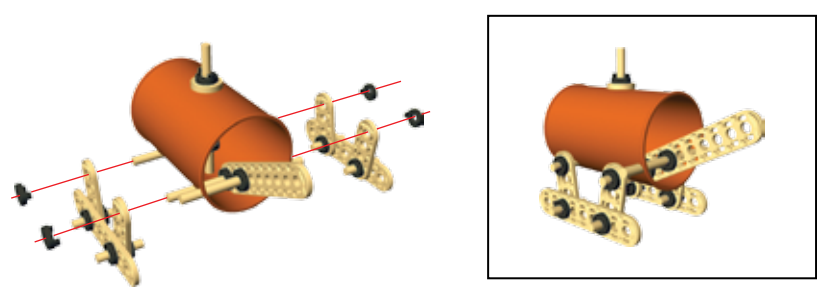

7. _____

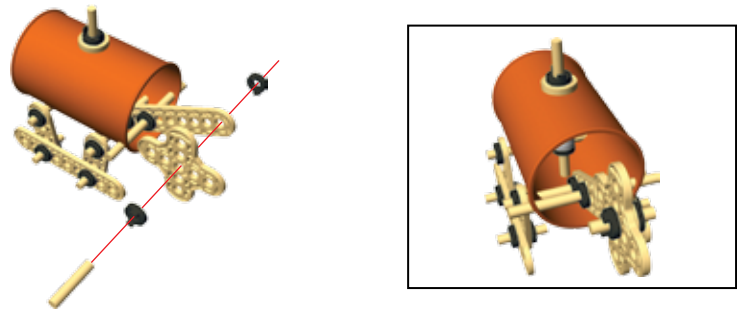

8. _____



Plane

ENGINEERING
CHALLENGE
#3

ENGINEERING
CHALLENGE
#4

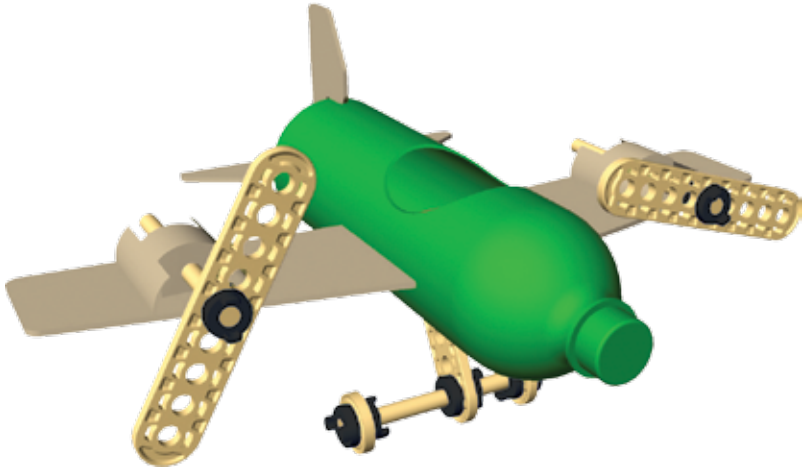
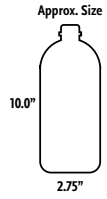

Parts needed:

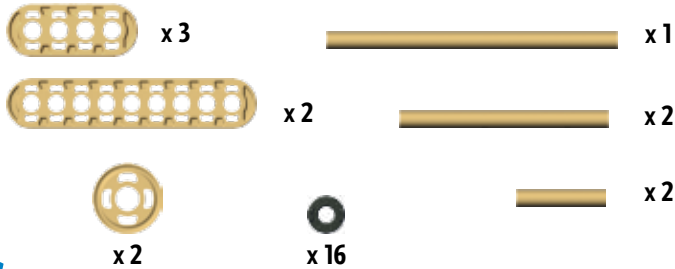

Tools:



1.

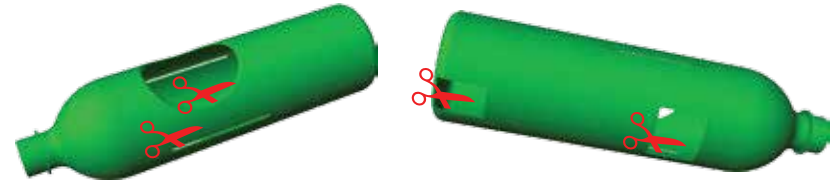

2.

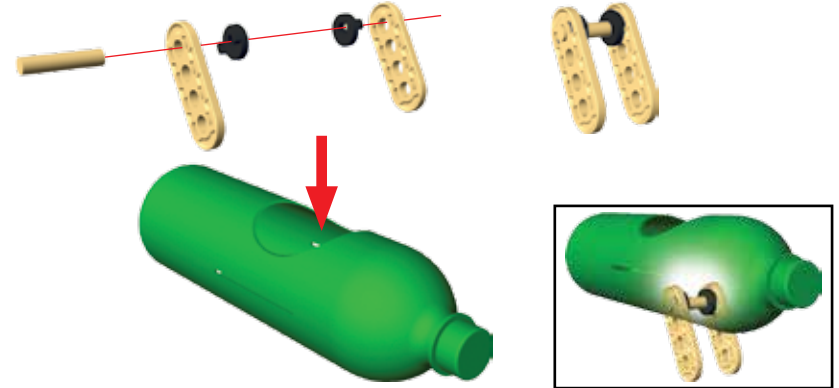

3.

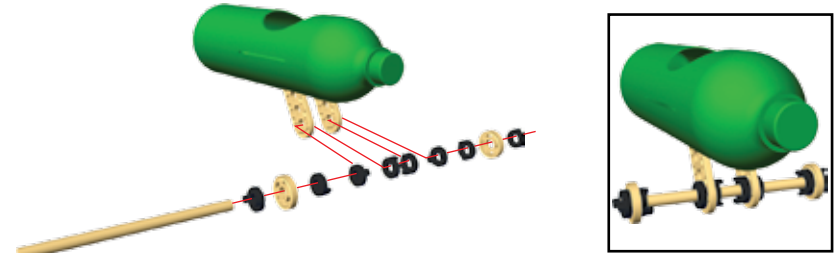

4.

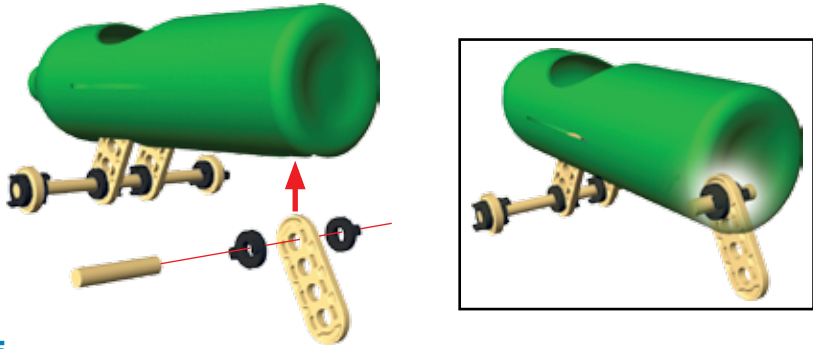

5.

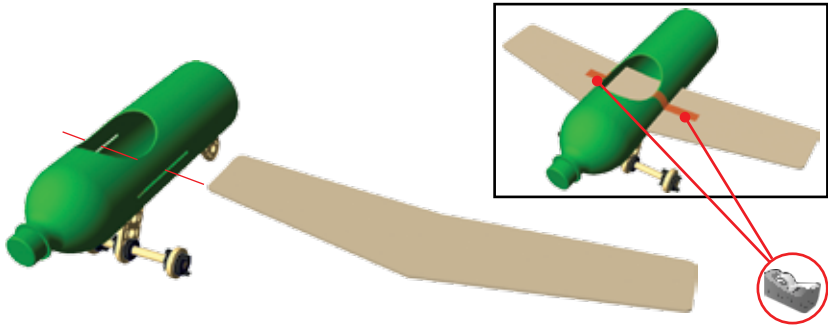

6.

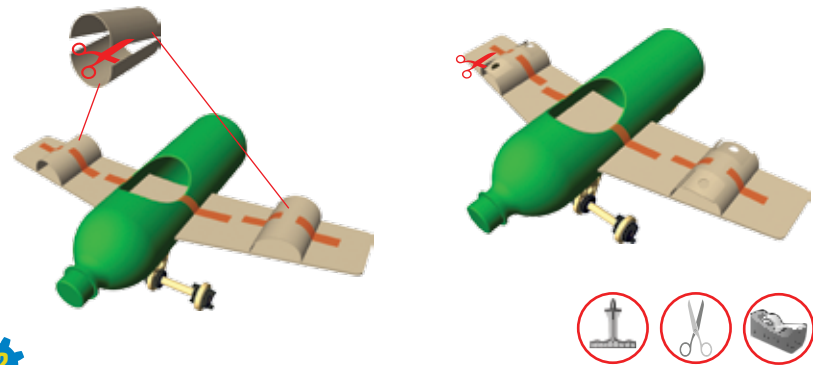

7.

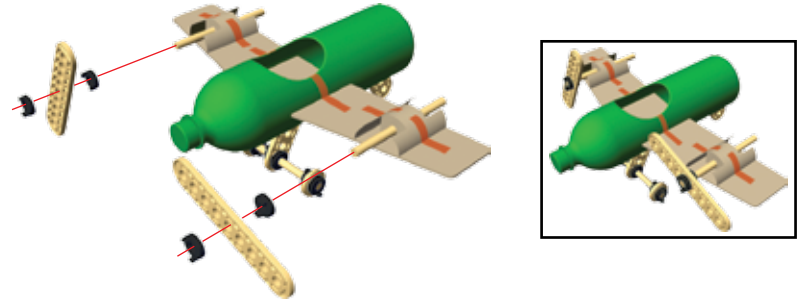

8.

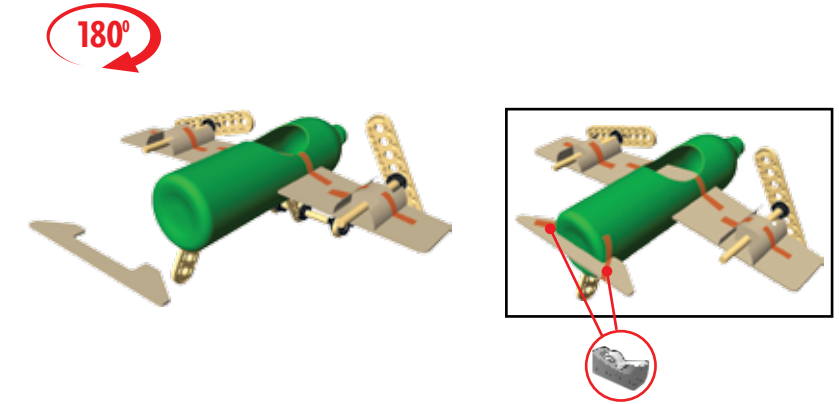

9.

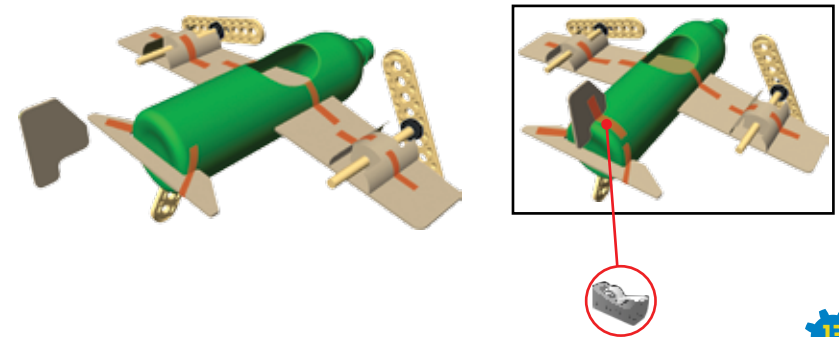

Biplane

ENGINEERING
CHALLENGE
#5

ENGINEERING
CHALLENGE
#6

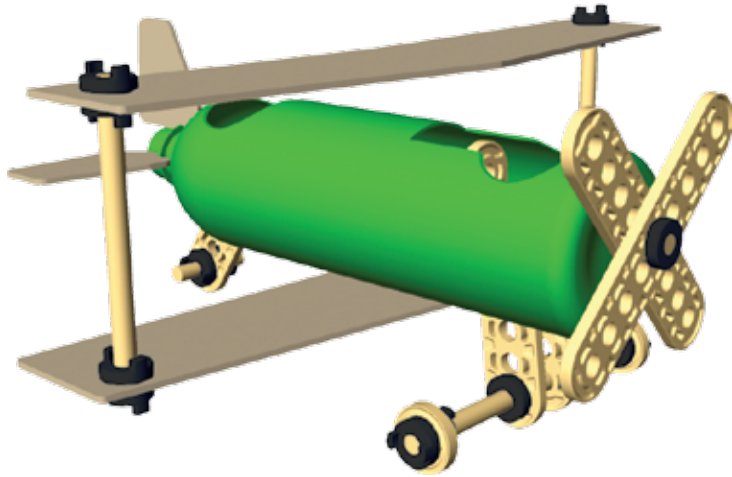
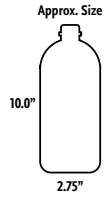

Parts needed:



Tools:



1.

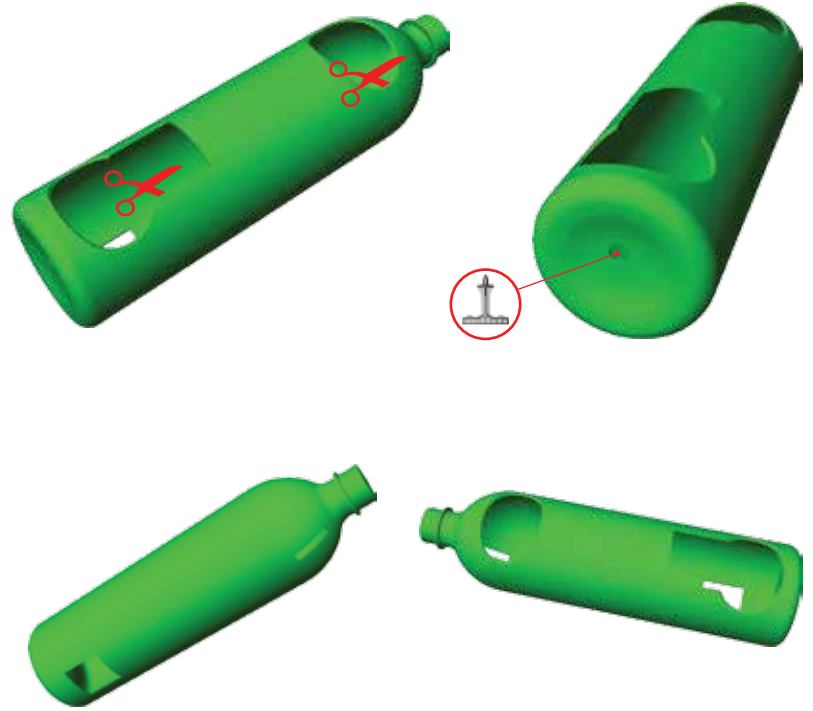

3.

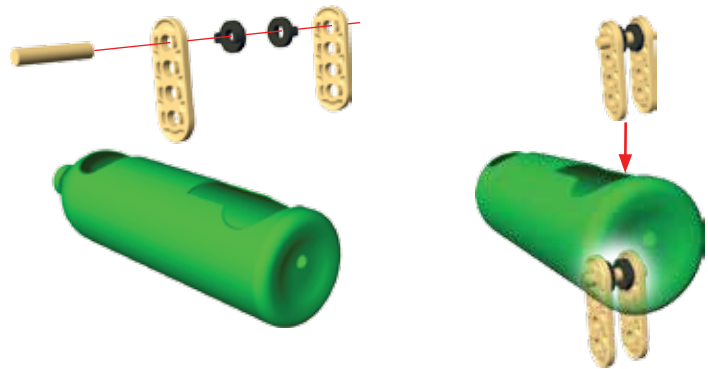

4. _____

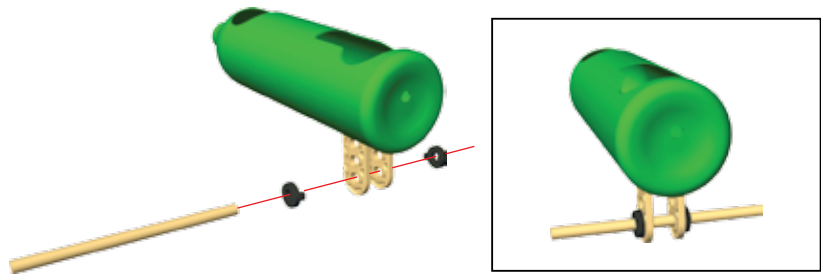

5. _____

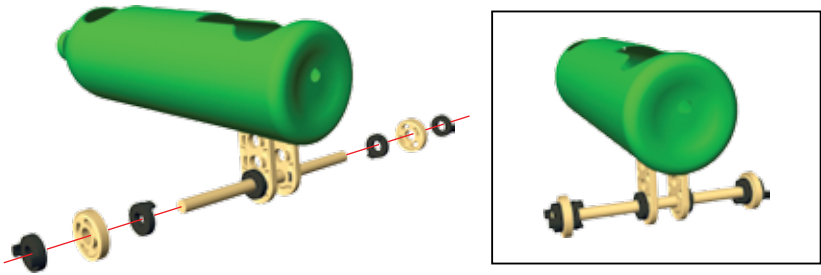

6. _____

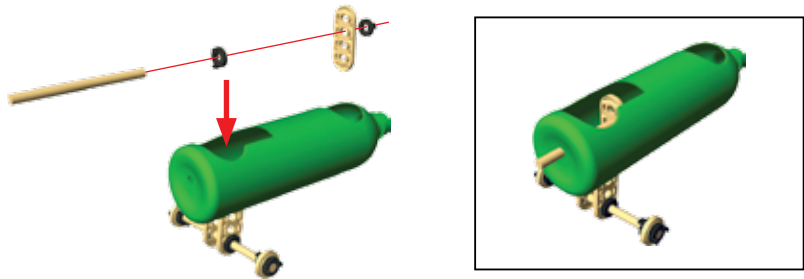

7. _____

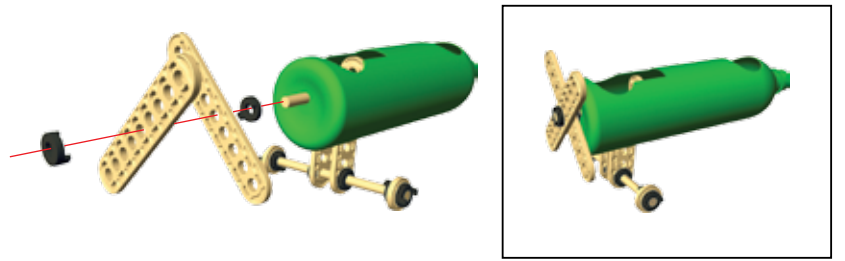

8. _____

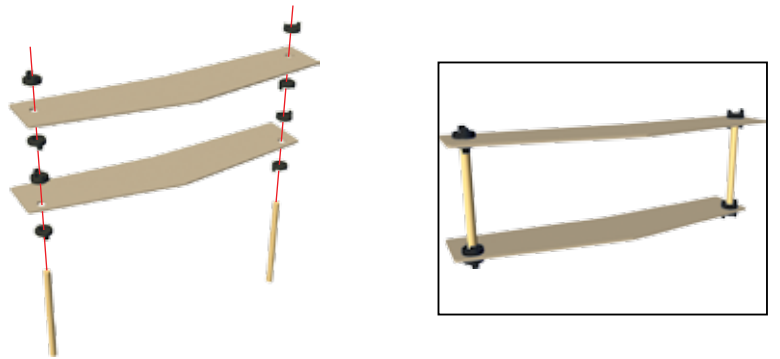

9. _____

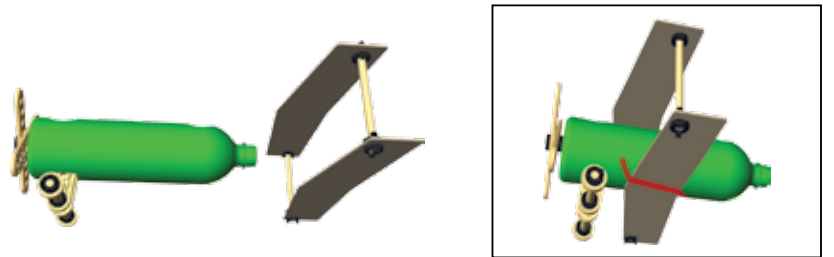

10.

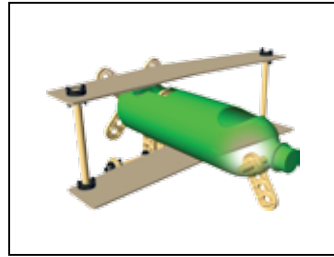
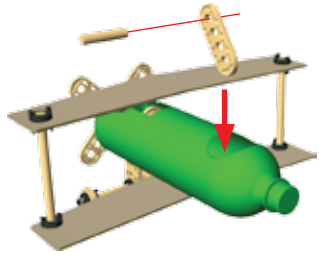

11.

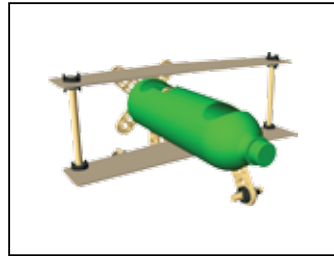
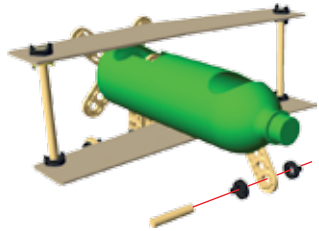

12.

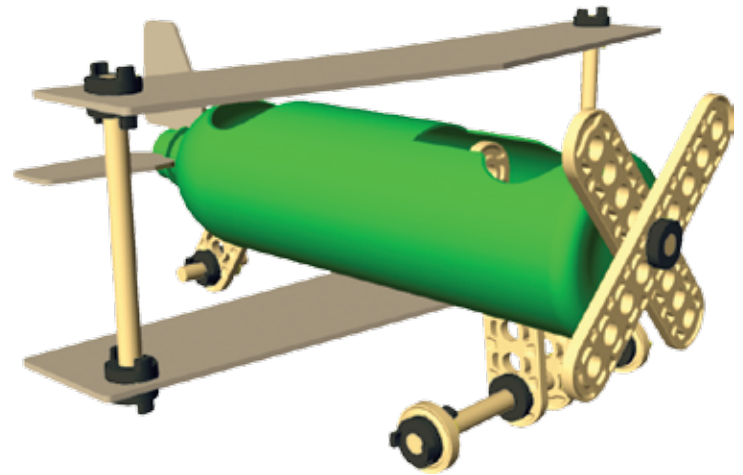
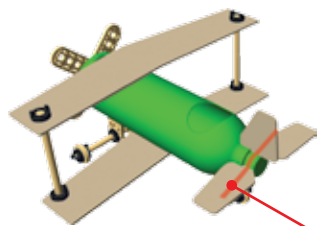

Windmill

ENGINEERING
CHALLENGE
#7

ENGINEERING
CHALLENGE
#8

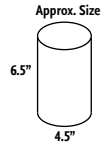

Parts needed:

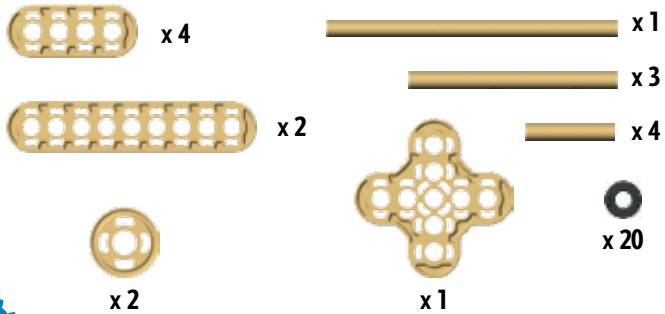

Tools:



1.

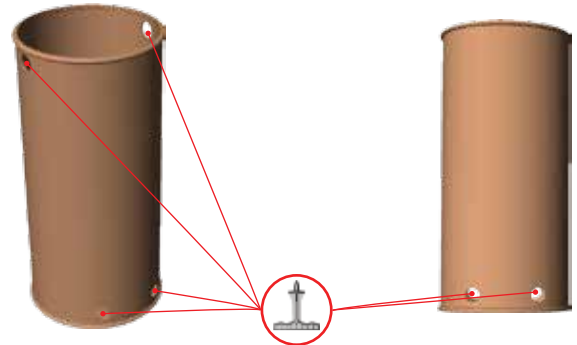

2.

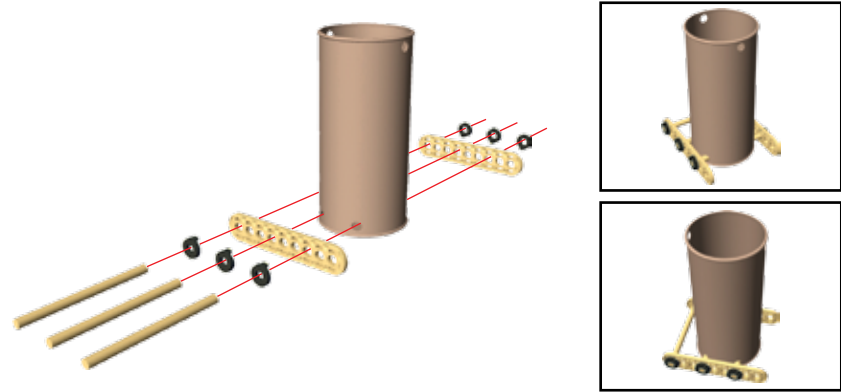

3.

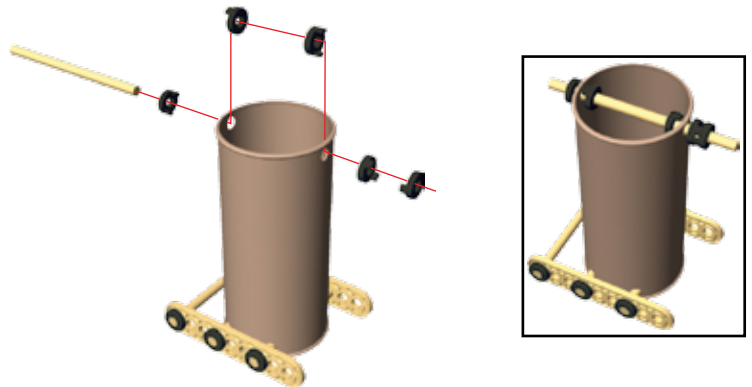

4.

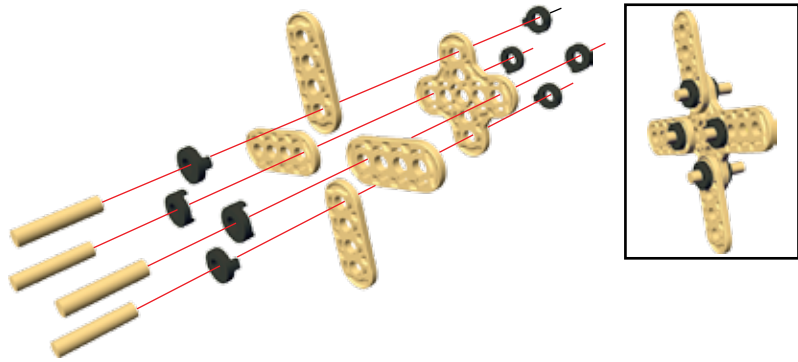

5.

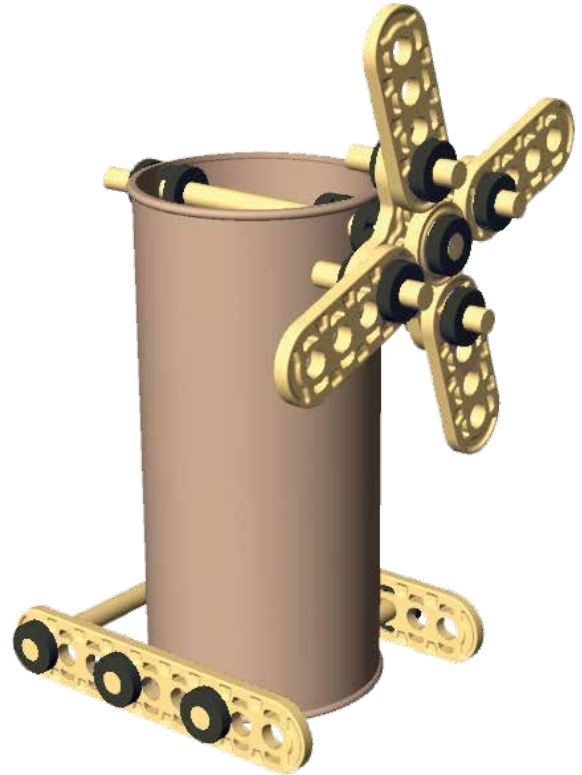
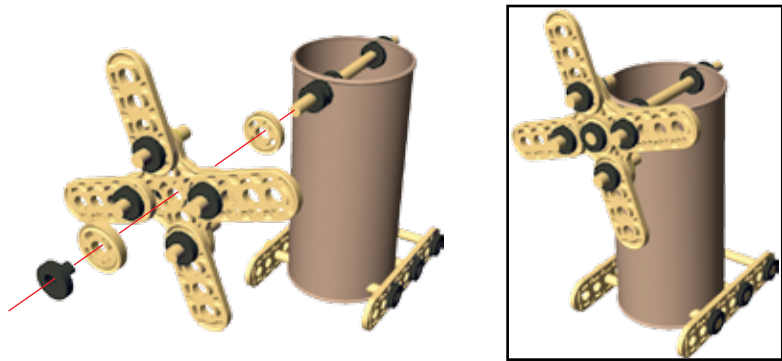

ThinkFun's Mission is to Ignite Your Mind!®

ThinkFun® is the world's leader in addictively fun games that stretch and sharpen your mind. From lighting up young minds to creating fun for the whole family, ThinkFun's innovative games and mobile apps make you think while they make you smile.



www.ThinkFun.com

